

Z3U-V05-W-a7-120



FEATURES

- Three super bright genuine SAMSUNG LED in each module
- Two-sided adhesive tape for peeling
- High efficiency led lighting products with less consumption of energy, more brightness
- Long life-span over 50,000 hours under Interone own high-technologies
- Reliable and qualified products meet global standards such as UL,CE,CB, and more



DIMENSION

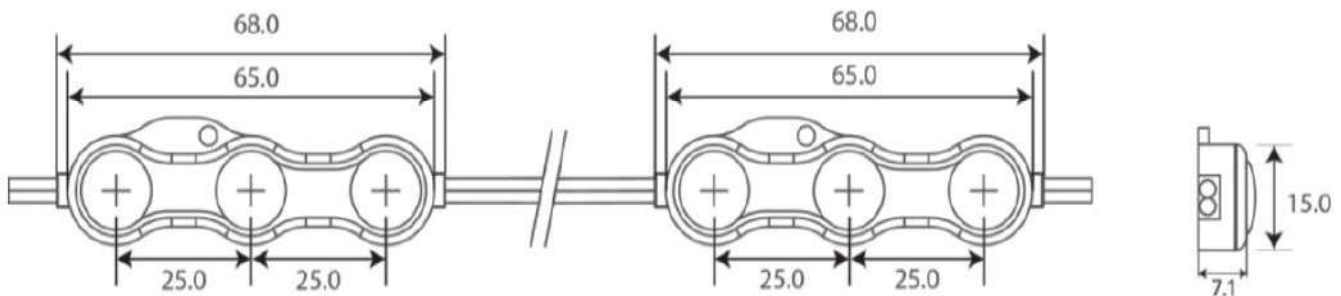

Z3U-V05-W-a7-120

TECHNICAL SPECIFICATION

OPERATION VOLTAGE	DC 12V
POWER CONSUMPTION	1.2W
CURRENT	100mA
VIEWING ANGLE	170
COLOUR RENDERING INDEX	80
BEAM ANGLE	170
WEIGHT	7g
LIFESPAN	~50000h
OPERATION TEMPERATURE	-30~70C
IP RATING	IP68
COMPLIANCE WITH	CE / RoHS / UL / KS / SASO / BIS
WARRANTY	5 Years

CCT/LUMEN

CCT	LIGHT COLOR	LM	LM/W
3000K	WARM WHITE	105	88
4000K	NATURAL WHITE	105	88
6500K	PURE WHITE	106	89
9000K	COOL WHITE	110	91
11000K	COLD WHITE	110	91

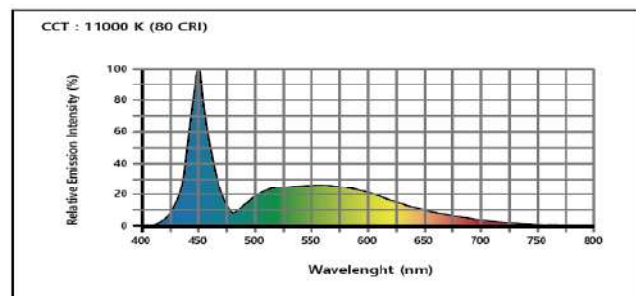
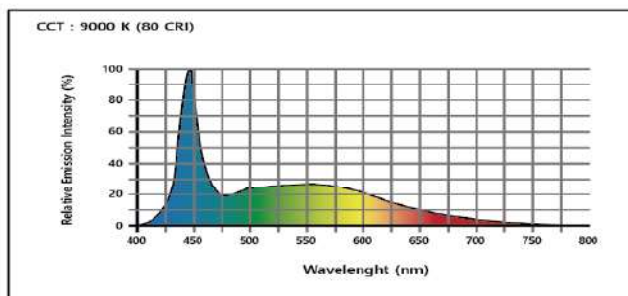
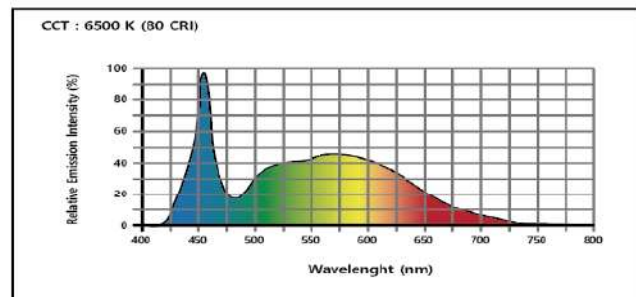
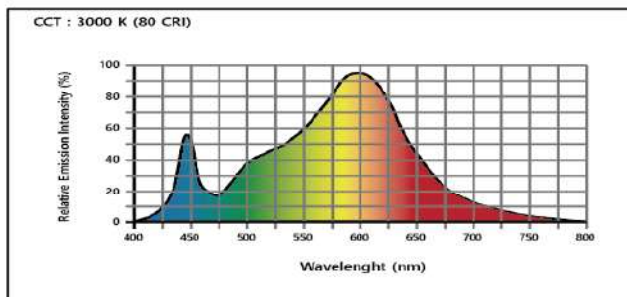

Z3U-V05-W-a7-120

INSTALLATION GUIDE

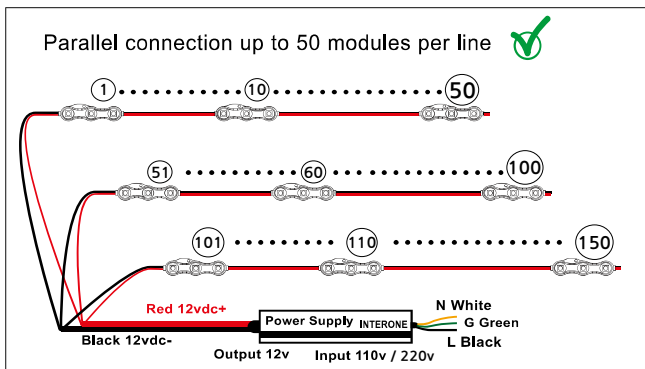
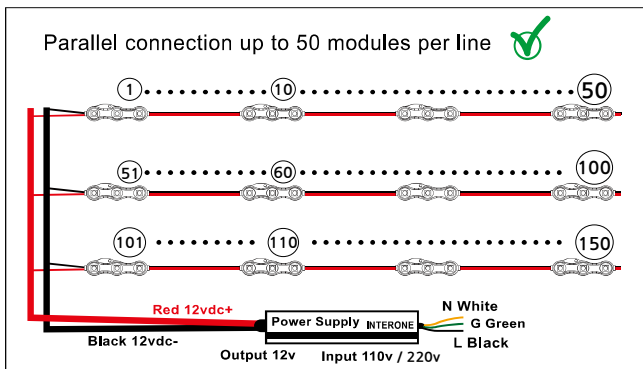
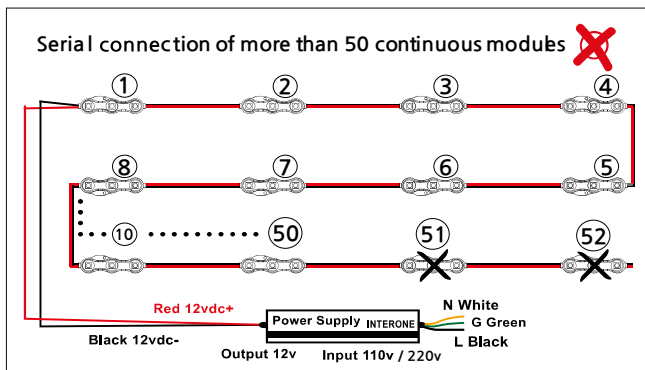
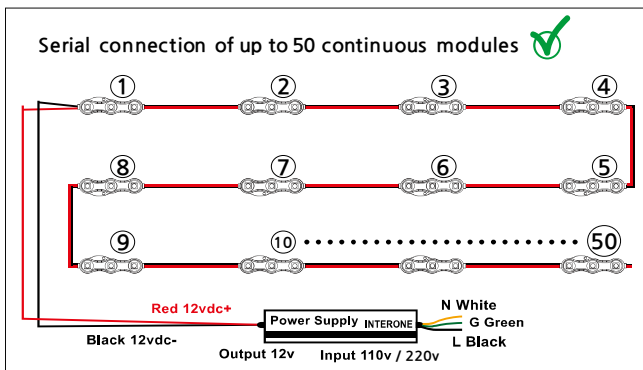
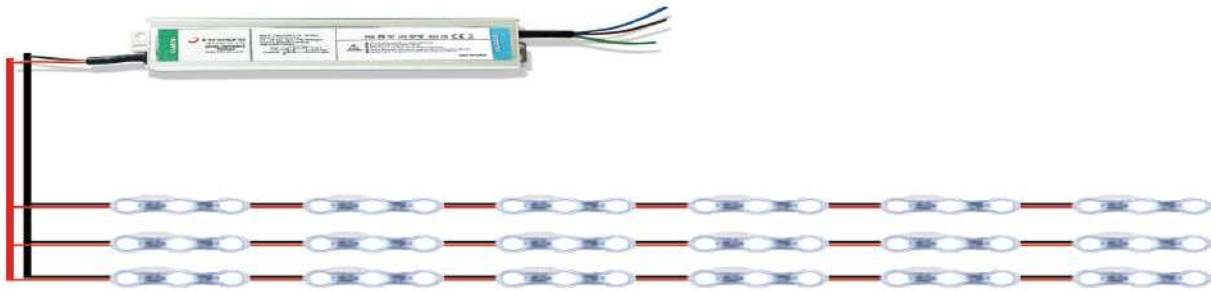

Module	Power Supply 100W	Power Supply 150W	Power Supply 200W	Power Supply 300W
0.72 W	111 ea	167 ea	222 ea	333 ea
1.20 W	67 ea	100 ea	133 ea	200 ea
1.44 W	56 ea	83 ea	111 ea	167 ea

INSTALLATION GUIDELINE

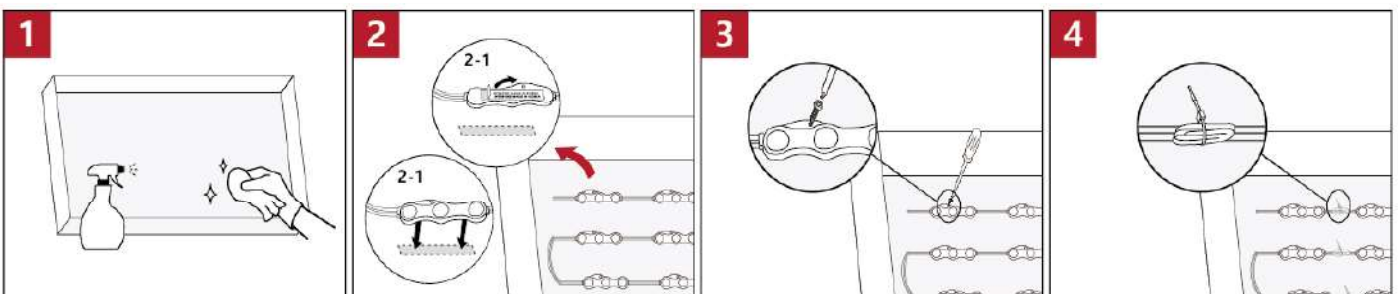

Z3U-V05-W-a7-120



PRODUCT

Part 1 High Luminous Efficiency

High light effective; No light decay after working 1000Hrs'
With 50,000Hrs lifespan
Adopt Genuine LED package from SAMSUNG and SEOUL-SEMICONDUCTOR



Part 3 Lens

Patented unique Peanut Shape of beam angle, various options to choose upon the request



Part 4 - Molding

Zero solder - Patented Wire-Thru® and Reverse-Circuit Protection make high durability & outstanding quality

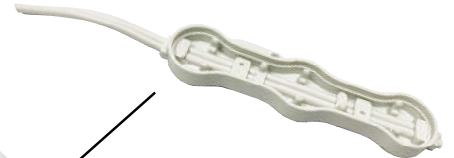

Part 2 High Quality PCB board

Mounting process made from surface mount technology expertised experts with ideal pitching size

Part 5 Adhesive tape on the back

(Satisfying the standard of ASTM, Same model as the one supply to Hyundai-Motors)



Part 6 High-quality Wire

True AWG 18 Copper Wire (99.99%)

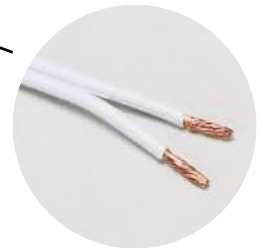

PACKAGING DIMENSION

ZIPPER BAG : 200 PCS

CARTON BOX : 2,000 PCS (15 KG)

